

7820 SolarisTM

Bar Code Scanner

User's Guide

Disclaimer

Honeywell International Inc. (“HII”) reserves the right to make changes in specifications and other information contained in this document without prior notice, and the reader should in all cases consult HII to determine whether any such changes have been made. The information in this publication does not represent a commitment on the part of HII.

HII shall not be liable for technical or editorial errors or omissions contained herein: nor for incidental or consequential damages resulting from the furnishing, performance, or use of this manual.

This document contains proprietary information that is protected by copyright. All rights reserved. No part of this document may be photocopied, reproduced, or translated into another language without the prior written consent of HII.

© 2007 - 2011 Honeywell International Inc. All rights reserved.

Web Address: www.honeywellaidc.com

Trademarks

MetroSelect, MetroSet2, Metrologic, and Solaris are trademarks or registered trademarks of Metrologic Instruments, Inc. or Honeywell International Inc.

Microsoft, Windows 95, and Windows are registered trademarks of Microsoft Corporation.

IBM is a trademark of International Business Machines Corporation.

Checkpoint is a registered trademark of Checkpoint Systems, Inc.

Sensormatic is a registered trademark of Sensormatic Electronics Corporation.

Other product names mentioned in this manual may be trademarks or registered trademarks of their respective companies and are the property of their respective owners.

Patents

For patent information, please refer to www.honeywellaidc.com/patents.

TABLE OF CONTENTS

INTRODUCTION

Product Overview	1
Applications and Protocols	2
Scanner and Accessories	3
Basic Kit Components	3
Optional Accessories	3
Scanner and Accessories	4
7820 Scanner Design Specifications	7

BASE MODEL CHARACTERISTICS

7820 Scanner	9
Components	9
Dimensions	10
Connector Panel	10
Caution and Serial Number Label	11

INSTALLATION

Cable Installation (Interface Specific)	12
Keyboard Wedge	12
USB	13
RS232	14
RS485	15
Cable Installation (Secondary Metrologic Scanner)	16
EAS Deactivation	19
Flex Stand Installation, PN 46-00868	20
Wall Mount Stand Installation, PN 46-00869	23

SCANNER OPERATION

Scan Zone	27
Depth of Field by Minimum Bar Code Element Width	28
Indicator Descriptions	32
Audible	32
Visual	33
Failure Modes	34
Diagnostic Indicator Display	35
Power Save Modes	36
Touch Button Panel	37

TABLE OF CONTENTS

MAINTENANCE

Replaceable Protective Outer Window.....	38
Daily Maintenance.....	38

TROUBLESHOOTING GUIDE

Troubleshooting Symptom / Solution Chart.....	39
---	----

CONFIGURATION MODES.....44

UPGRADING THE FIRMWARE45

SCANNER AND CABLE TERMINATIONS

Scanner Pinout Connection.....	46
Cable Connector Configurations (Host End).....	48

REGULATORY COMPLIANCE

Safety.....	50
EMC.....	51
Class A Devices.....	51
Class B Devices.....	52

CUSTOMER SUPPORT53

LIMITED WARRANTY.....55

INDEX56

INTRODUCTION

PRODUCT OVERVIEW

The 7820 Solaris™ vertical mini-slot scanner increases productivity with an unmatched feature set that aggressively scans high-density codes and fits easily into any existing enclosure found in small item, high-volume retail environments. Every scanner comes standard with an integrated RF EAS antenna, Checkpoint® and Sensormatic interlock and the ability to be remotely configured or Flash upgraded. These features, in combination with multiple on-board interfaces and a diagnostic display, make the 7820 ideal for retailers seeking a lower total cost of ownership on their next scanner investment. Firmware updates are easily loaded into Flash memory.

The 7820 bar code scanner is equipped with a multitude of standard features including:

- Automatic Scanning Operation
- EAS Deactivation Antenna
- Supports Multiple Interfaces (USB, KBW, RS232, RS485)
- Custom Parsing Bar Code Data
- OPOS and JPOS System Compatible
- RS232 Auxiliary Port for Adding Peripherals (Scanners or Scales)
- User Replaceable Cables
- Coplanar Scanner Surface
- Sunrise 2005 Compliant
- Single-Digit Diagnostic Indicator
- Remote Management Capabilities

INTRODUCTION

APPLICATIONS AND PROTOCOLS

The model number on each scanner includes the scanner number and factory-default communications protocol.

SCANNER	COMMUNICATION PROTOCOL(S)
7820	RS232, Keyboard Wedge, USB, Auxiliary, RS485

The 7820 bar code scanner with Built-in PC Keyboard Wedge Interface is designed to be used for keyboard emulation only. Many RS232 configurable functions available in other Honeywell scanners are also available as keyboard wedge functions.

The following are the most important selectable options specific to the keyboard wedge.

Keyboard Type

- AT (includes IBM® PS2 models 50, 55, 60, 80)
- IBM PS2 (includes models 30, 70, 8556)

Keyboard Country Type

- *USA
- Belgium
- French
- German
- Hungarian
- Italian
- Japanese
- Russian Cyrillic
- Slovenian
- Spanish
- Swiss
- Swedish/Finnish
- Turkish
- United Kingdom

INTRODUCTION

SCANNER AND ACCESSORIES

BASIC KIT COMPONENTS	
Part #	Description
MS7820	Bar Code Scanner
00-02407	MetroSelect® Configuration Guide
00-02283	7820 Bar Code Scanner User's Guide
57-57312-3	7820 EAS Cable - Checkpoint (External)
57-57313-3	7820 EAS Cable - Sensormatic (External)
<i>Guides also available for download at www.honeywellaidc.com.</i>	
OPTIONAL ACCESSORIES	
Part #	Description
7820 Scanner Interface Cables	
5S-5Sxxx-3*	Straight, VLink Cable with short strain relief
5S-5Sxxx-N-3*	Straight, Direct Cable with short strain relief
5S-5S002-3	Keyboard Wedge VLink Cable with Adapter Cable
5S-5S006-N-3	RS485 (IBM) Direct Cable
5S-5S213-N-3	USB Direct 12V (Type A Plus Power) Cable
5S-5S235-3	USB 12VLink Cable (Type A)
57-57499-3	RS232 Scanner AUX 12VLink Cable
57-57500-N-3	RS232 Scale AUX Cable (Mettler-Toledo Viva)
57-57501-N-3	AUX Cable (MT Viva Scale Handheld Scanner)
<i>xxx*</i>	<i>Specifies connection to the host.</i>
<i>Contact a customer service representative for additional information. See page 53 for contact information.</i>	

INTRODUCTION

SCANNER AND ACCESSORIES

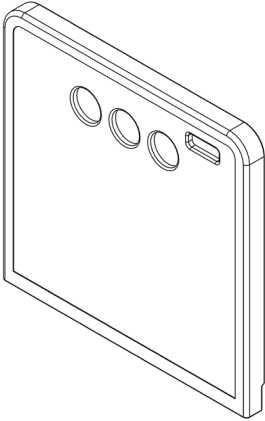
OPTIONAL ACCESSORIES	
Part #	Description
AC to DC Power Transformer – Regulated 12V@ 1.25A output	
46-00862	Power Supply, United States / Japan
46-00863	Power Supply, Continental Europe
46-00864	Power Supply, United Kingdom
46-00865	Power Supply, China
46-00866	Power Supply, Australia
Part #	Description
7800 External Window Option	
46-00867	7800 Replaceable Protective Outer Window
	
<p>** For 7800 Replacement Protective Outer Window removal / installation instructions see page 38 of this manual.</p>	
<p><i>Other items may be ordered for the specific protocol being used. To order additional items, contact the dealer, distributor, or customer service. See page 53 for contact information.</i></p>	

INTRODUCTION

SCANNER AND ACCESSORIES

OPTIONAL ACCESSORIES	
Part #	Description
46-00868	7820 Flex Stand Kit
Flex Stand, Kit Components	
<p>1. Tall Flex Pole Cover Qty. 1</p> <p>2. Tall Flex Pole..... Qty. 1</p> <p>3. Stand Base..... Qty. 1</p> <p>4. Plastic Stand Base Cover..... Qty. 1</p> <p>5. M4 x 0.7 x 10-10N Flat Head Screw..... Qty. 2</p> <p>6. #8 x 1.00" Wood Screw..... Qty. 4</p> <p>7. 1/4" Lock Washer Qty. 2</p>	

INTRODUCTION

SCANNER AND ACCESSORIES

OPTIONAL ACCESSORIES	
Part #	Description
46-00869	7820 Wall Mount Stand Kit
Wall Mount Stand, Kit Components	
1. Short Flex Pole.....	Qty. 1
2. Short Flex Pole Cover	Qty. 1
3. Plastic Housing	Qty. 1
4. Plastic Stand Base Cover.....	Qty. 1
5. Wall Mounting Bracket	Qty. 1
6. 1/4" Lock Washer.....	Qty. 2
7. M4 x 0.7 x 10-10N Flat Head Screw.....	Qty. 3
8. #8 x 1.00" Wood Screw	Qty. 4

Other items may be ordered for the specific protocol being used. To order additional items, contact the dealer, distributor, or customer service. See page 53 for contact information.

INTRODUCTION

7820 SCANNER DESIGN SPECIFICATIONS

	7820 SERIES DESIGN SPECIFICATIONS
OPERATIONAL	
Light Source:	Visible Laser Diode (VLD) @ 650 nm
Laser Power:	0.900 mW (peak)
Depth of Field:	0 mm to 255.0 mm (0"- 10.0") for 0.33 mm (13 mil) bar code
Width of Scan Field:	38 mm (1.5") @ 15 mm (0.6"); 135 mm (5.3") @ 191 mm (7.5")
Scan Speed:	1800 scans/second
Scan Pattern:	5 fields of 4 parallel lines (omnidirectional)
Scan Lines:	20
Min Bar Width:	0.127 mm (5.0 mil)
Decode Capability:	Auto-discriminates all standard bar codes; for other symbologies contact a customer service, see page 53.
System Interfaces:	Keyboard Wedge, RS232, USB, RS485
Print Contrast:	35% minimum reflectance difference
No. Characters Read:	up to 80 data characters (Maximum number will vary based on symbology and density)
Roll, Pitch, Yaw:	360°, 60°, 60°
Beeper Operation:	7 tones or no beep
Indicators (LED):	Blue = laser on, ready to scan, and good read.
MECHANICAL	
Dimensions:	152 mm (6.0") H, 92 mm (3.6") D, 152 mm (6.0") W
Footprint of Stand	152 mm (6.0") x 64 mm (2.5")
Weight:	0.706 Kg (1.56 lbs)
Termination:	Two: 10-pin modular RJ45 jacks One: 6-pin modular RJ45 jack
Cable:	Standard 2.1m (7') straight; for other cables contact a customer service representative, see page 53.

INTRODUCTION

7820 SCANNER DESIGN SPECIFICATIONS

	7820 SERIES DESIGN SPECIFICATIONS
ELECTRICAL	
Input Voltage:	12VDC \pm 0.25V
Power:	4.8 W
Operating Current:	320 mA
DC Transformers:	Class II; 12VDC @ 1.25A
<i>For Regulatory Compliance information, see pages 50 - 52.</i>	
ENVIRONMENTAL	
Operating Temperature:	0°C to 40°C (32°F to 104°F)
Storage Temperature:	-40°C to 60°C (-40°F to 140°F)
Humidity:	5% to 95% relative humidity, non-condensing
Light Levels:	Up to 4842 LUX (450 foot candles)
Contaminants:	Sealed to resist airborne particulate contaminants
Ventilation:	None required

BASE MODEL CHARACTERISTICS

7820 SCANNER

Components

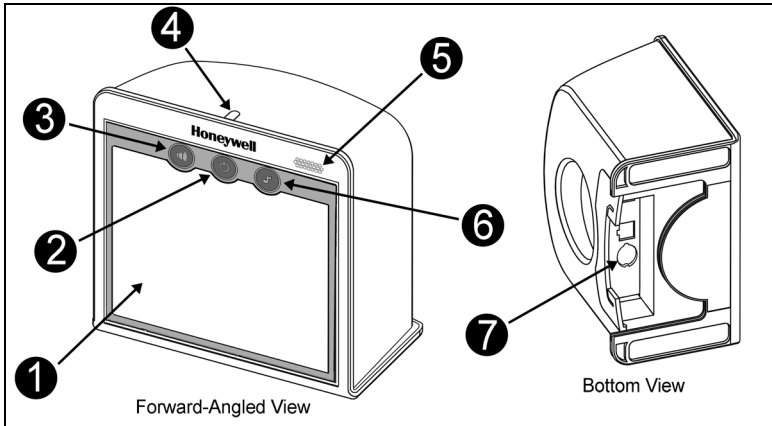

Figure 1. 7820 Bar Code Scanner Parts

①	Scratch Resistant Output Window (Laser Aperture)
②	Power Save Button
③	Volume Button
④	Blue Indicator LED
⑤	Speaker
⑥	Tone Button
⑦	Cable Connection Area

BASE MODEL CHARACTERISTICS

7820 SCANNER

Dimensions

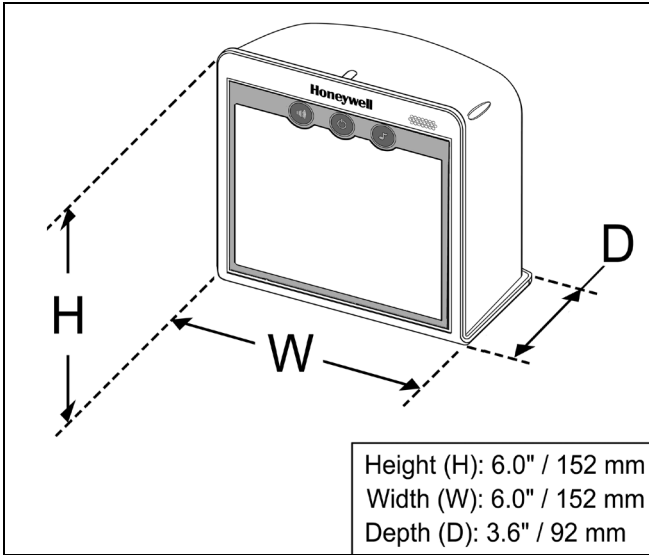

Figure 2. 7820 Bar Code Scanner Dimensions

Connector Panel

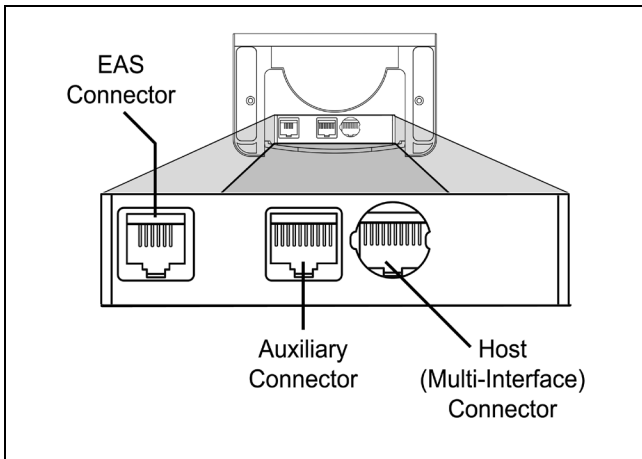

Figure 3. 7820 Connector Panel Layout

BASE MODEL CHARACTERISTICS

7820 SCANNER

Caution and Serial Number Labels

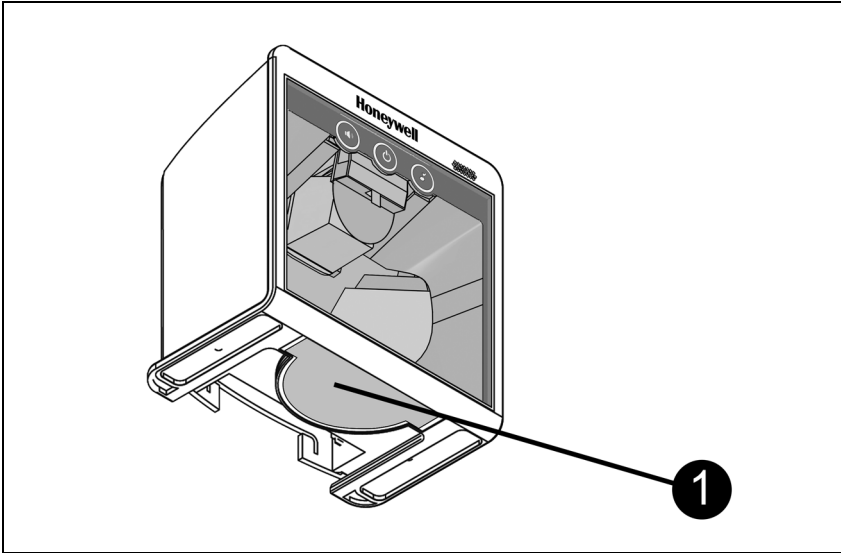
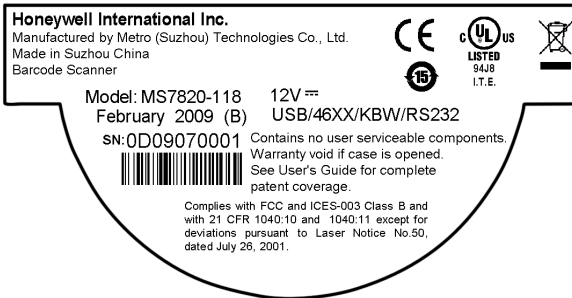

Figure 4. 7820 Label Location (Top) & Sample Label (Below)



Caution

To maintain compliance with applicable standards, all circuits connected to the scanner must meet the requirements for SELV (Safety Extra Low Voltage) according to EN/IEC 60950-1.

To maintain compliance with standard CSA C22.2 No. 60950-1/UL 60950-1 and norm EN/IEC 60950-1, the power source should meet applicable performance requirements for a limited power source.

INSTALLATION

CABLE INSTALLATION (INTERFACE SPECIFIC)

Keyboard Wedge

1. Turn off the host system.
2. Disconnect the keyboard from the host.
3. Connect the keyed VLink cable to the 10-pin Multi-Interface jack. It is the only circular keyed jack located on the bottom of the 7820 (see figure 5).
4. Connect the “Y” end of the VLink cable to the keyboard and the keyboard port on the host. If necessary, use the male/female adapter cable supplied with the scanner.



Before continuing, verify the VLink cable is connected to the appropriate interface jack on the scanner. An incorrect cable connection can cause communication problems or potential damage to the scanner.

5. Connect the external power supply to the power jack on the scanner.
6. Check the AC input requirements of the power supply to make sure the voltage matches the AC outlet.
7. Connect AC power to the transformer. The outlet should be near the equipment and easily accessible.
8. Scan the *Recall Defaults* bar code to configure the 7820 for Keyboard Wedge communication.
9. Turn on the host system.
10. Snap on the cable cover.

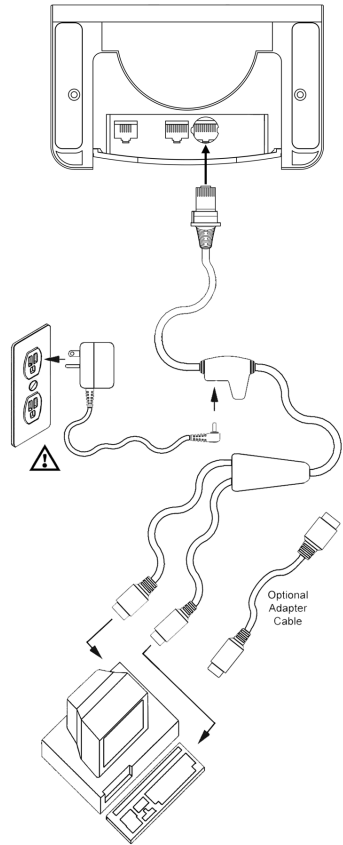

Figure 5.
Keyboard Wedge Interfaces



See SELV Power caution statement located on page 11 of this manual.

INSTALLATION

CABLE INSTALLATION (INTERFACE SPECIFIC)

USB

1. Connect the keyed VLink cable to the 10-pin Multi-Interface jack. It is the only circular keyed jack located on the bottom of the 7820 (see figure 6).
2. Connect the other end of the USB cable to the host.



Before continuing, verify the USB cable is connected to the appropriate interface jack on the scanner. An incorrect cable connection can cause communication problems or potential damage to the scanner.



Plugging the scanner into the USB port of the PC does not guarantee that scanned information will appear at the PC. A software driver and correct configuration setting may also be required for proper communication depending on settings.

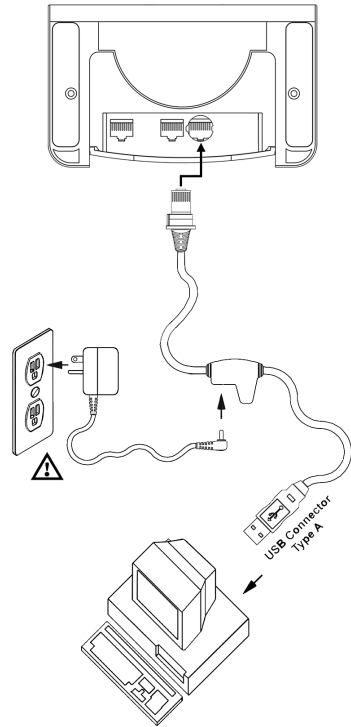

Figure 6. USB, Interface

3. Scan the *Recall Defaults* bar code to configure the 7820 for USB communication.
4. Turn on the host system.
5. Snap on the cable cover.

For additional communication options for USB interfaces refer to the MetroSelect Configuration Guide (PN 00-02407).



See SELV Power caution statement located on page 11 of this manual.

INSTALLATION

CABLE INSTALLATION (INTERFACE SPECIFIC)

RS232

1. Turn off the host system.
2. Connect the keyed VLink cable to the 10-pin Multi-Interface jack. It is the only circular keyed jack located on the bottom of the 7820 (see figure 7).
3. Connect the other end of the VLink cable to the host.



Before continuing, verify the VLink cable is connected to the appropriate interface jack on the scanner. An incorrect cable connection can cause communication problems or potential damage to the scanner.

4. Connect the external power supply to the power jack on the scanner.
5. Check the AC input requirements of the power supply to make sure the voltage matches the AC outlet.
6. Connect AC power to the transformer. The outlet should be near the equipment and easily accessible.
7. Scan the *Recall Defaults* bar code to configure the 7820 for RS232 communication.
8. Turn on the host system.
9. Snap on the cable cover.

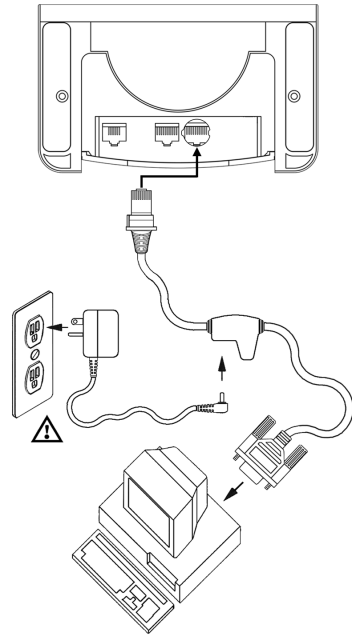

Figure 7. RS232 Interface



See SELV Power caution statement located on page 11 of this manual.

INSTALLATION

CABLE INSTALLATION (INTERFACE SPECIFIC)

RS485

1. Turn off the host system.
2. Connect the keyed cable to the 10-pin Multi-Interface jack. It is the only circular keyed jack located on the bottom of the 7820 (see figure 8).
3. Connect the other end of the cable to the host.

STOP Before continuing, verify the cable is connected to the proper communication jack on the scanner. Incorrect cable connection can cause communication problems or potential damage to the scanner.



Plugging the scanner into the serial port of the PC does not guarantee that scanned information will appear at the PC. A software driver and correct configuration setting are also required for proper communication to occur.

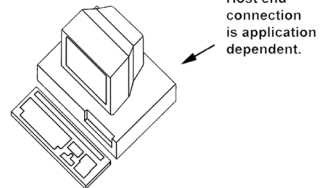
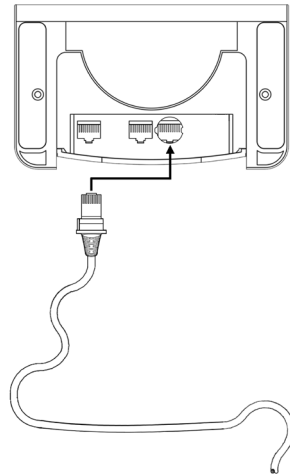

Figure 8. RS485 Interface

4. Turn on the host system.
5. Scan the *Recall Defaults* bar code to configure the 7820 for RS232/IBM communication.
6. Snap on the cable cover

For additional communication options for IBM interfaces refer to the MetroSelect Configuration Guide (PN 00-02407).



See SELV Power caution statement located on page 11 of this manual.

INSTALLATION

CABLE INSTALLATION (SECONDARY HONEYWELL SCANNER)

1. Turn off the host system.
2. Connect the round end of the *VLink RS232 AUX* cable [PN 57-57499-3] to the RS232 jack of the auxiliary scanner (see figure 9 on page 18).
3. Connect the other end of the *VLink RS232 AUX* cable into the Auxiliary (*AUX*) jack, which is located directly next to the circular keyed Multi-Interface jack. The Auxiliary (*AUX*) jack has a **square** opening.

The following Honeywell scanners can be used in the Auxiliary (*AUX*) input of the 7820: the MS9520, MS9540, MS7120, MS7220 or another 7820.

 Important: The 7820 aux port requires the signals: transmit, receive, RTS & CTS from the auxiliary scanner.

4. Connect the 7820/Host VLink* cable to the circular keyed Multi-Interface jack located on the bottom of the 7820.
5. Connect the other end of the 7820/Host VLink cable to the Host.
6. Connect the external power supply to the power jack on the VLink cable.
7. Check the AC input requirements of the power supply to make sure the voltage matches the AC outlet.
8. Snap on the cable cover.
9. Connect AC power to the transformer. The outlet should be near the equipment and easily accessible.
10. Configure the 7820 for the appropriate interface configuration settings.*

* The 7820/host cable connection is interface dependent. Refer to the installation steps provided for the type of interface (*RS232, RS485, etc.*) required for your application.



See SELV Power caution statement located on page 11 of this manual.

INSTALLATION

CABLE INSTALLATION (SECONDARY HONEYWELL SCANNER)

11. Scan the following bar code to configure the auxiliary port on the 7820 to accept a Honeywell scanner as the secondary scanner.



The following bar codes **do not apply** when using an MS6720 as a secondary scanner. If the secondary scanner is not a Honeywell scanner, refer to the *Auxiliary Port Control* section of the MetroSelect Configuration Guide.



The auxiliary input port's data format must match the main output format of the secondary scanner.

12. Scan the following bar codes, in order, to configure the secondary scanner to match the auxiliary port's data format.

1st

Enable AUX Output



2nd

Secondary Scanner Data Format



3rd

Enable Comm Timeouts



4th (Optional)

Turn OFF Secondary Scanner's Beeper



13. Turn on the host system.

INSTALLATION

CABLE INSTALLATION (SECONDARY HONEYWELL SCANNER)

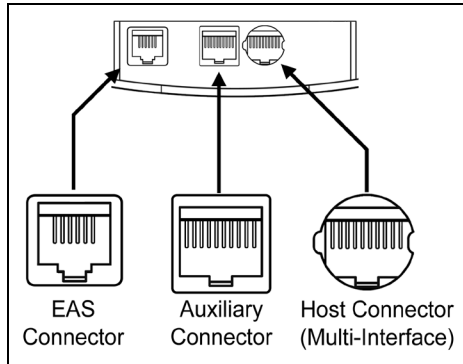
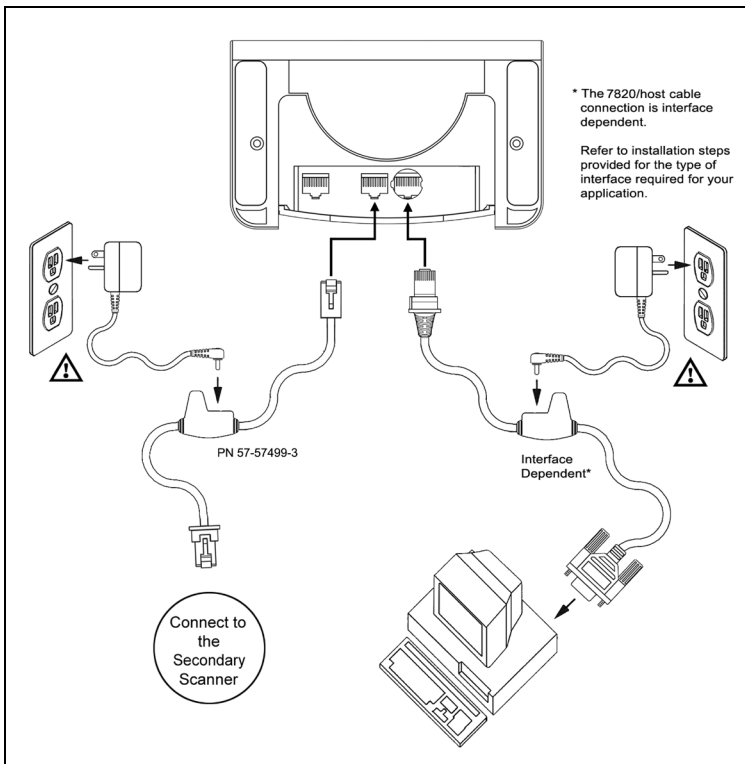

Figure 9. Connector Orientation (Top)
Auxiliary Scanner Setup (Bottom)



See SELV Power caution statement located on page 11 of this manual.

INSTALLATION

EAS DEACTIVATION

SW1 and SW2 are the switch banks inside the Checkpoint device that set the deactivation range. Honeywell recommends end users program the 7820 bar code scanner to the *Short Range**, so that the unit does not scan out beyond the deactivation range.

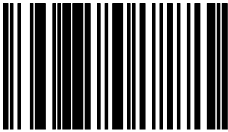
Unit #	Checkpoint Recommended Switch Bank Settings	7820 Depth of Field Recommended Settings
7820	SW1 - 2, 3, 4, 5, 6 set to ON & SW2 - 2, 3, 4, 5, 6 set to ON	<p data-bbox="713 456 857 480">Short Range*</p>  <p data-bbox="671 618 900 634">3 1 1 8 7 1 1</p>
<p data-bbox="157 670 905 695">* Note: Minimum element width changes to 6.8 mil when in this mode.</p>		

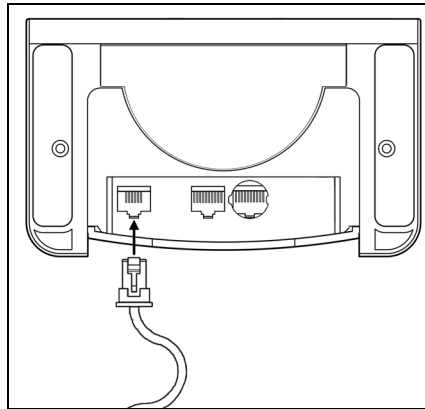

Figure 10. EAS Deactivation Antenna

Contact Checkpoint Systems directly for additional EAS support.

INSTALLATION

FLEX STAND INSTALLATION, PN 46-00868

1. Drill four #39 pilot holes in the counter top for the stand base plate.

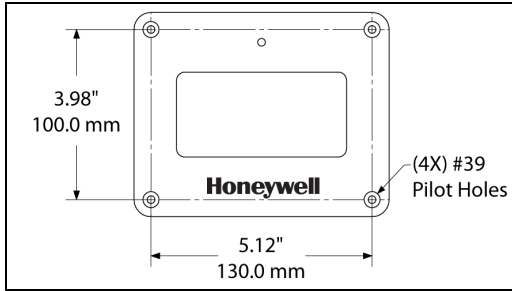

Figure 11. Base Plate Hole Pattern

2. Attach the flex pole assembly and secure the base plate to the counter. Slide the flex cover over the flex pole assembly. Once the flex pole has been assembled, mount the stand base plate to the counter and install the flex cover over the flex pole assembly.

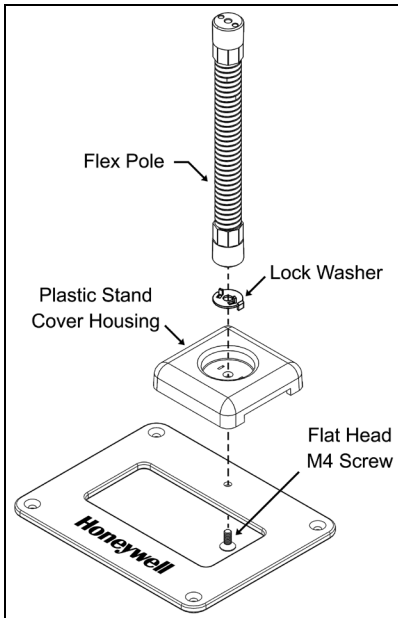

Figure 12. Pole Assembly

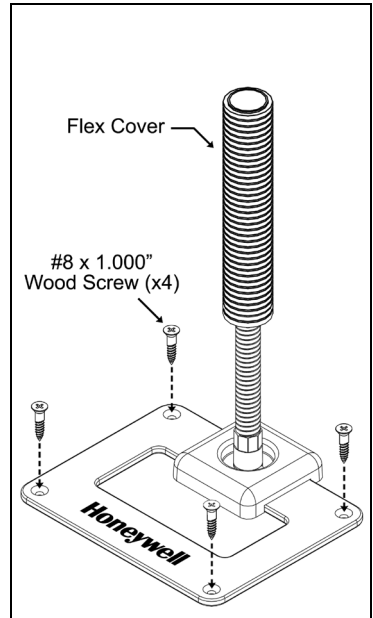

Figure 13. Cover Assembly

INSTALLATION

FLEX STAND INSTALLATION

3. Remove the scanner's back plate from the rear side of the unit. Apply pressure to the points shown in *Figure 14* until the back plate unlatches from the scanner.

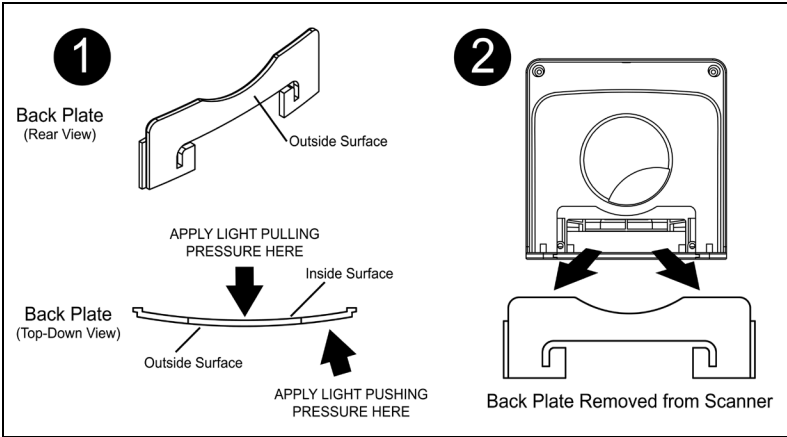

Figure 14. Cable Cover Removal

4. Slide the bottom mounting plate off the scanner.

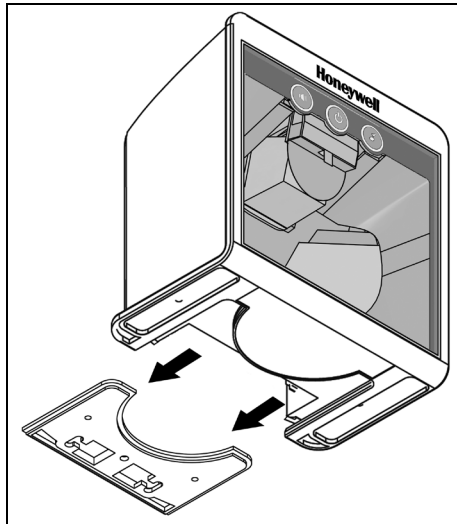

Figure 15. Mounting Plate Removal

INSTALLATION

FLEX STAND INSTALLATION

5. Attach the scanner mounting plate to the flex pole.

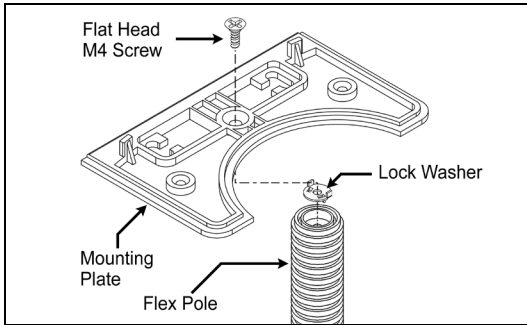

Figure 16. Secure mounting plate to flex pole.

6. Slide the scanner onto the mounting plate until the plate is fully seated into the scanner.

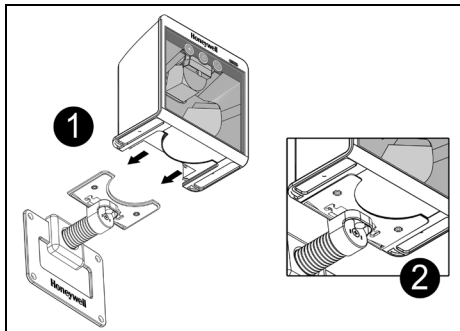

Figure 17. Slide mounting plate into scanner.

7. **Before** installing the scanner's cable cover, refer to pages 12-19 for instructions on the proper cable connections.

8. Re-Install the scanner's back plate to lock-in the bottom mounting plate.

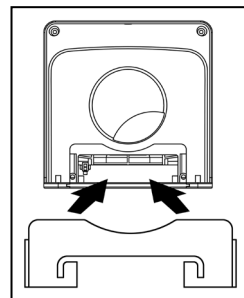

Figure 18. Install back plate

INSTALLATION

WALL MOUNT STAND INSTALLATION, PN 46-00869

1. Locate the area on the wall where the scanner will be mounted and drill four #39 pilot holes in the wall for the stand base plate.

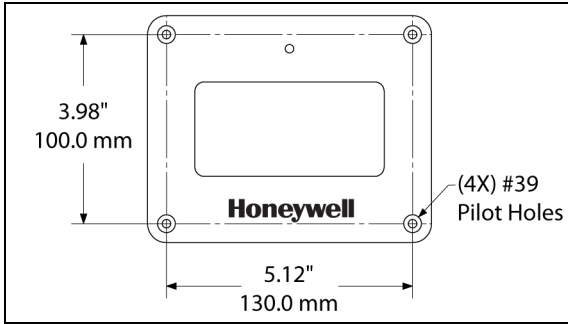

Figure 19. Base Plate Hole Pattern

2. Attach the flex pole assembly to the Wall Mount plate. Slide the flex cover over the flex pole assembly.

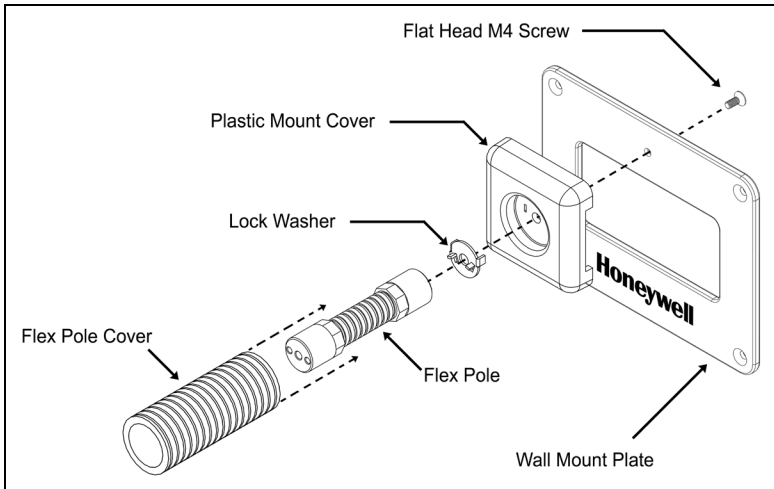

Figure 20. Pole Assembly

INSTALLATION

WALL MOUNT STAND INSTALLATION

3. Remove the scanner's back plate from the rear side of the unit. Apply pressure to the points shown in *Figure 21* until the back plate unlatches from the scanner.

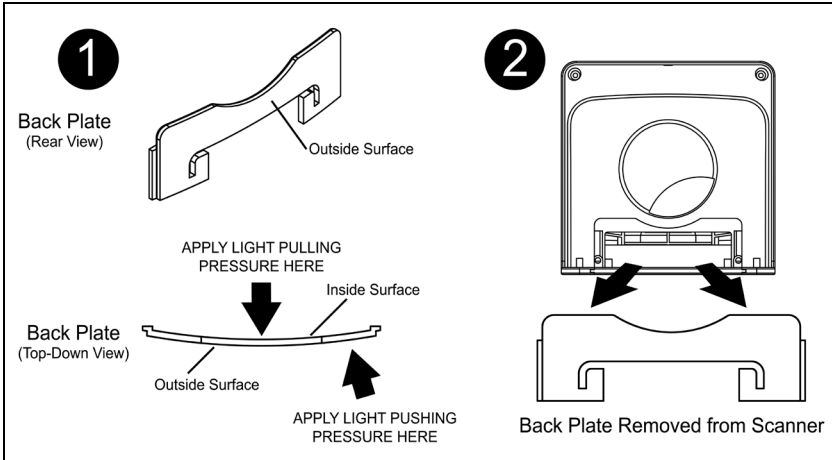

Figure 21. Cable Cover Removal

4. Slide the bottom mounting plate off the scanner.

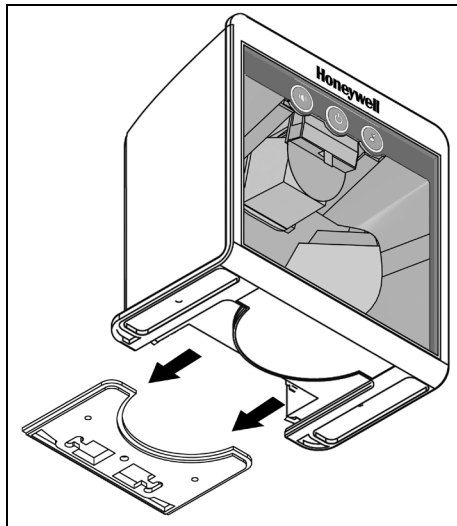

Figure 22. Mounting Plate Removal

INSTALLATION

WALL MOUNT STAND INSTALLATION

- Secure the wall mounting plate to the wall location designated in Step 1 and assemble the remaining parts as shown in *Figure 23*.

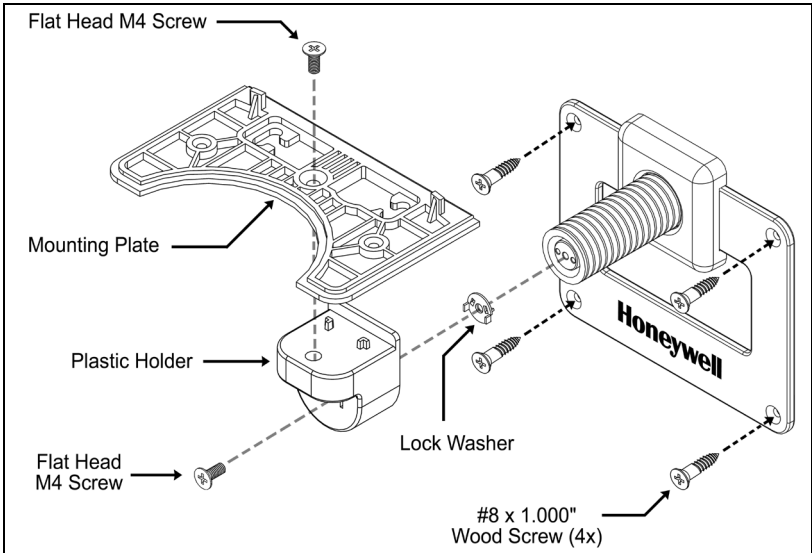

Figure 23. Scanner Mounting Plate Assembly

- Slide the scanner onto the mounting plate until the plate is fully seated into the scanner.

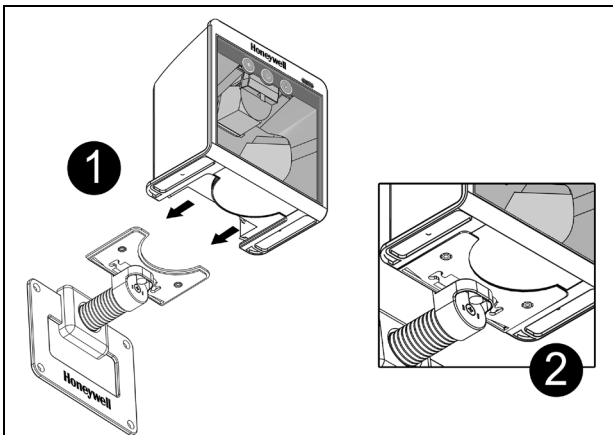

Figure 24. Slide mounting plate into scanner.

INSTALLATION

WALL MOUNT STAND INSTALLATION

7. **Before** installing the scanner's cable cover, refer to pages 12-19 for instructions on the proper cable connections.
8. Re-Install the scanner's back plate to lock-in the bottom mounting plate.

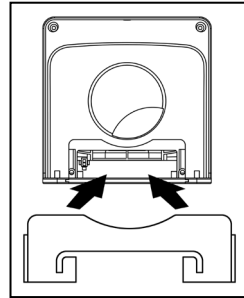

Figure 25. Install back plate

SCANNER OPERATION

SCAN ZONE (BASED ON 100% UPC BAR CODES)

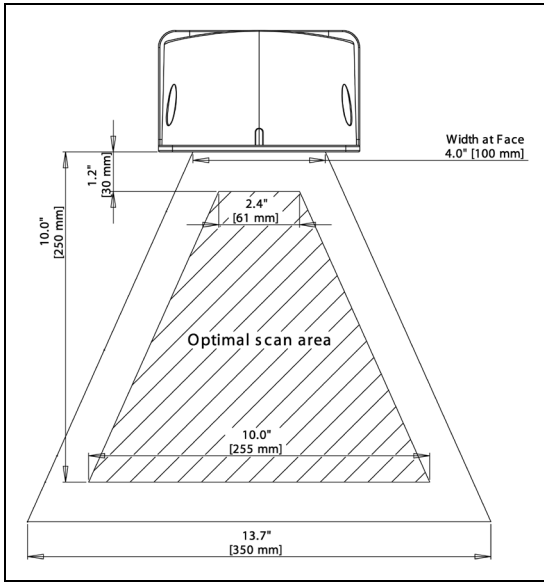
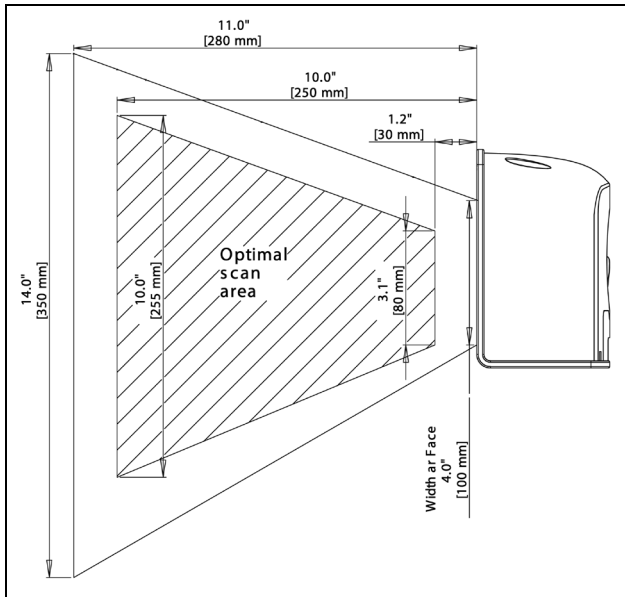

Figure 26. Scan Area Top View (top) Side View (bottom)



Specifications are subject to change without notice.

SCANNER OPERATION

DEPTH OF FIELD BY MINIMUM BAR CODE ELEMENT WIDTH (BASED ON 100% UPC BAR CODES)

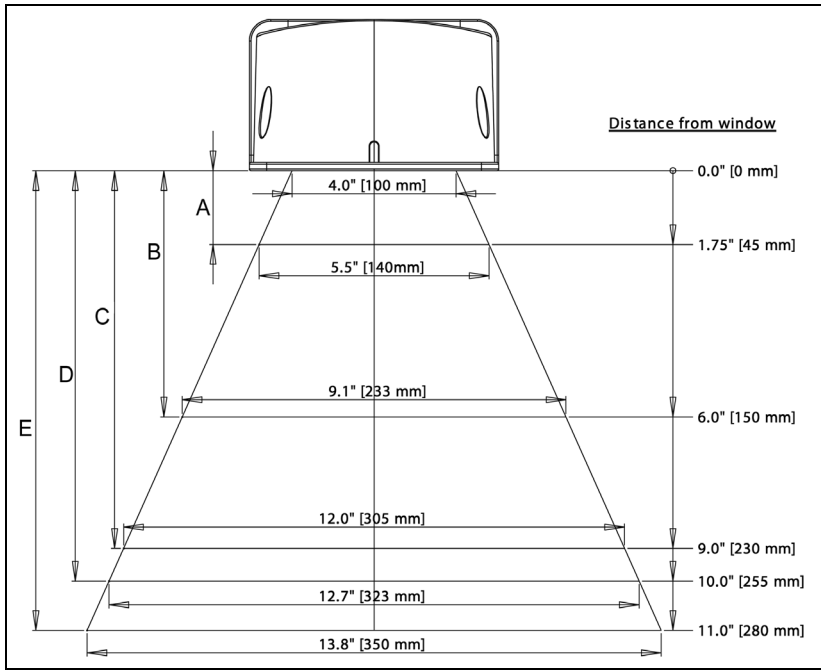

**Figure 27. Depth of Field Top View
Long Range Mode**

Minimum Bar Code Element Width Long Range Mode					
	A	B	C	D	E
mm	.132	.190	.264	.330	.660
mils	5.2	7.5	10.4	13.0	26.0

Specifications are subject to change without notice.

SCANNER OPERATION

DEPTH OF FIELD BY MINIMUM BAR CODE ELEMENT WIDTH (BASED ON 100% UPC BAR CODES)

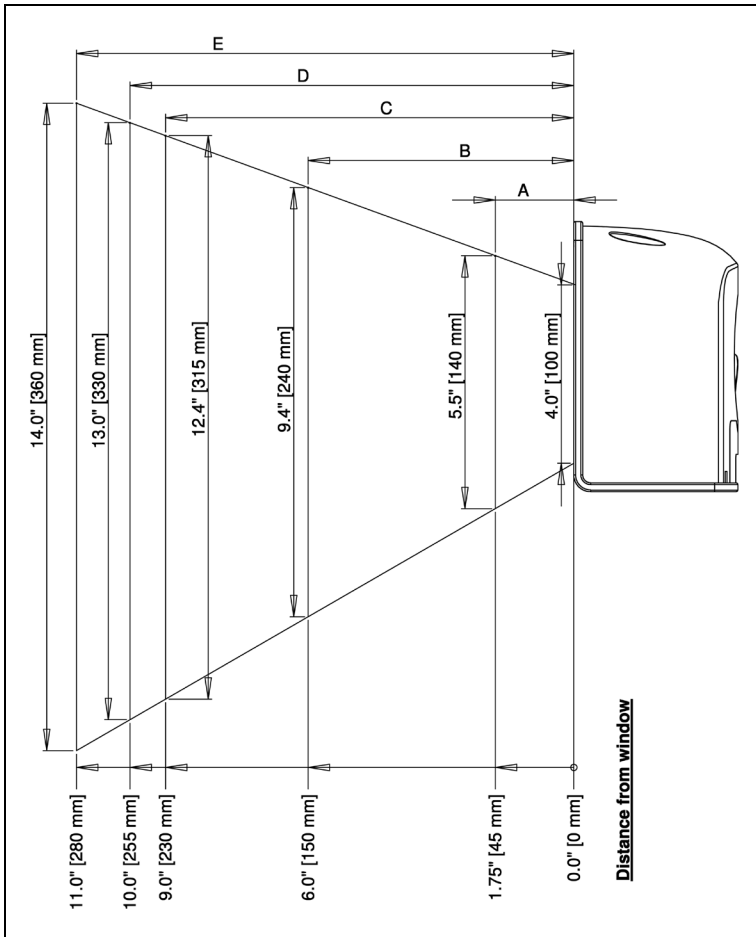

Figure 28. Depth of Field Side View
Long Range Mode

Minimum Bar Code Element Width Long Range Mode					
	A	B	C	D	E
mm	.132	.190	.264	.330	.660
mils	5.2	7.5	10.4	13.0	26.0

Specifications are subject to change without notice.

SCANNER OPERATION

DEPTH OF FIELD BY MINIMUM BAR CODE ELEMENT WIDTH (BASED ON 100% UPC BAR CODES)

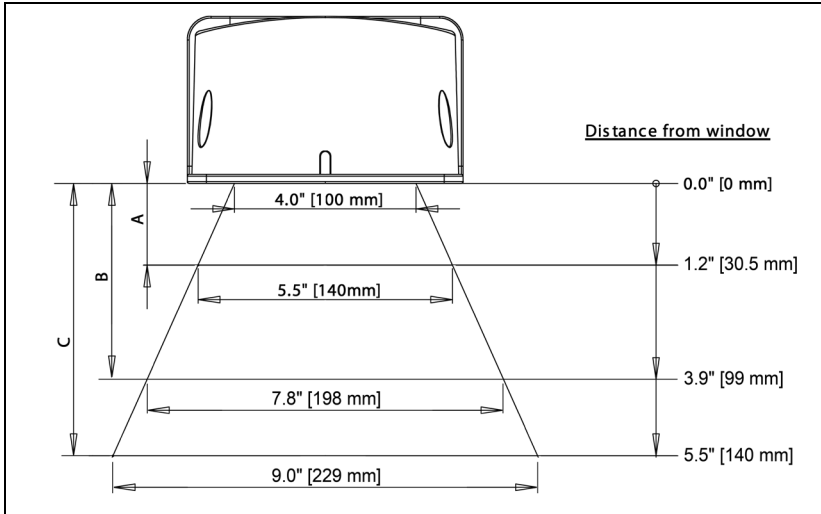

Figure 29. Depth of Field Top View
Short Range Mode

Minimum Bar Code Element Width			
Short Range Mode			
	A	B	C
mm	.190	.264	.330
mils	7.5	10.4	13.0

Specifications are subject to change without notice.

SCANNER OPERATION

DEPTH OF FIELD BY MINIMUM BAR CODE ELEMENT WIDTH (BASED ON 100% UPC BAR CODES)

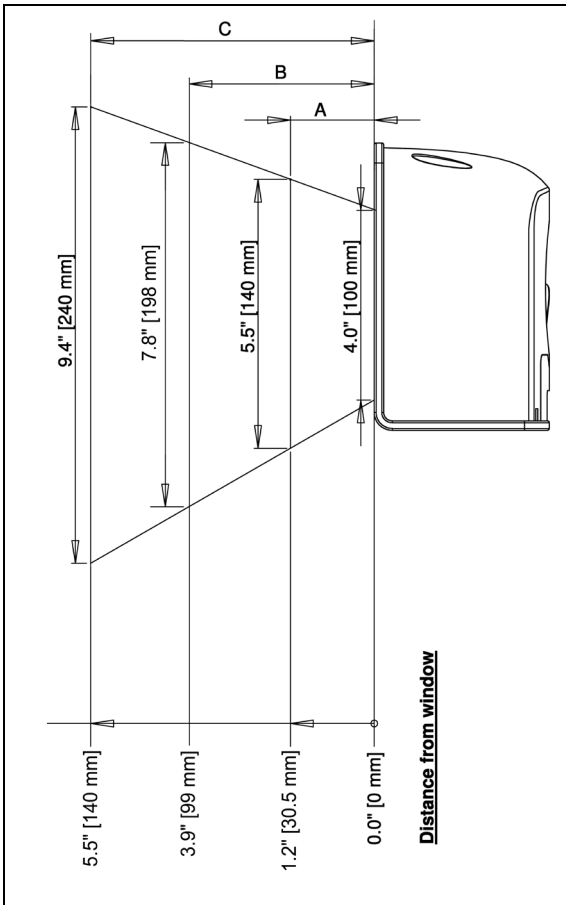

Figure 30. Depth of Field Side View
Short Range Mode

Minimum Bar Code Element Width Short Range Mode			
	A	B	C
mm	.190	.264	.330
mils	7.5	10.4	13.0

Specifications are subject to change without notice.

SCANNER OPERATION

INDICATOR DESCRIPTIONS

Audible

When the 7820 scanner is in operation, it provides audible feedback. These sounds indicate the status of the scanner. Eight settings are available for the tone of the beep (normal, 6 alternate tones and no tone). To change the tone, use the *Tone Button* or refer to the MetroSelect Configuration Guide.



One Beep

When the scanner *first* receives power, the blue LED will turn on and the scanner will beep once. The blue LED will remain on for the duration of the beep. The scanner is now ready to scan.

When the scanner *successfully* reads a bar code, the blue LED will flash and the scanner will beep once (if configured to do so). If the scanner does not beep once and the blue LED does not flash, then the bar code has *not* been successfully read.

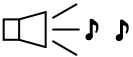

Two Beeps

The scanners programmed interface setting does not match the actual connected interface cable. This audible indicator will be heard during power up, or when a bar code is scanned.



Razzberry Tone

This is a failure indicator. Refer to failure modes on page 34.

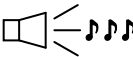

Three Beeps - during operation

When placing the scanner in program mode, the blue LED will flash while the scanner simultaneously beeps three times. The blue LED will continue to flash until the unit exits program mode. Upon exiting program mode, the scanner will beep three times and the LED will stop flashing.

When configured, three beeps can also indicate a communications timeout during normal scanning mode.

The scanner will beep three times in an ascending tone, with each beep higher in pitch than the previous. This tells the user that the single configuration bar code has *successfully* configured the scanner.

Three beeps will also occur during a manual adjustment of the beeper tone. The scanner will emit three evenly pitched/spaced tones with the blue indicator LED blinking in unison.

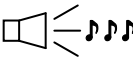

Three Beeps - on power up

This is a failure indicator. Refer to failure modes on page 34.

SCANNER OPERATION

INDICATOR DESCRIPTIONS

Visual

There is a blue LED on the top of the 7820 as well as three illuminated buttons on the front. When the scanner is on, the flashing or constant illumination of the LED indicates the status of the current scan and the scanner.

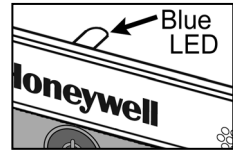

Figure 31. LED



No Blue LED

The LEDs will not be illuminated if the scanner is not receiving power from the host or transformer.

or

The unit is in Power Save Mode. During Power Save Mode, the laser will be off and the blue LED will not illuminate.



Steady Blue LED

When the laser is active, the blue LED is illuminated. The blue LED will remain illuminated until the laser is deactivated.

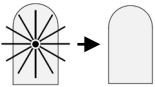

Steady Blue LED to OFF

After a successful scan, the scanner transmits the data to the host device. Some communication modes require that the host inform the scanner when data is ready to be received. If the host is not ready to accept the information, the scanner's blue LED will remain off until the data can be transmitted.



Single Blue LED Flash

When the scanner successfully reads a bar code, the blue LED will flash and the scanner will beep once. If the blue LED does not flash or the scanner does not beep once, then the bar code has not been successfully read.

The blue LED will also flash once while the EAS is in deactivation mode.

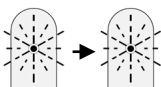

Flashing Blue LED

This indicates the scanner is in program mode. A flashing blue LED with razzberry tone indicates that an invalid bar code has been scanned during this mode.

INDICATOR DESCRIPTIONS

Failure Modes

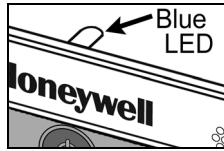
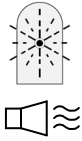
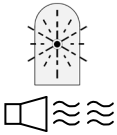

Figure 32. LED



Flashing BLUE LED and One Razzberry Tone

This indicates the scanner has experienced a laser subsystem failure. Return the unit for repair at an authorized service center.



Flashing Blue LED and Two Razzberry Tones

This indicates the scanner has experienced a motor failure. Return the unit for repair at an authorized service center.

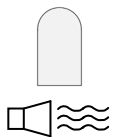

Continuous Razzberry Tone with LED off

If, upon power up, the scanner emits a continuous razzberry tone, then the scanner has an electronic failure. Return the unit for repair at an authorized service center.

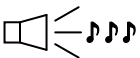

Three Beeps - on power up

The scanner beeps three times on power up indicates the nonvolatile memory, that holds the scanner configuration, has failed. Return the unit for repair at an authorized service center.

SCANNER OPERATION

INDICATOR DESCRIPTIONS

Diagnostic Indicator Display

There is a green colored (when illuminated) single digit error code display located to the left of the scanner's mirrored polygon (see figure to the right).

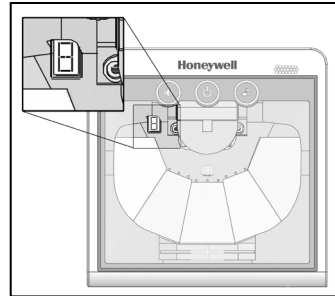

Figure 33. Failure LED

ERROR CODE	DESCRIPTION
0	RAM ERROR – The scanner's Random Access Memory (RAM) is tested as faulty. Return the unit for repair at an authorized service center.
1	PROGRAM ERROR – The scanner's software program is failing. Return the unit for repair.
2	INTERFACE ERROR – After power up and any application exit (e.g. MetroSet, etc.), the scanner checks the interface hardware with that chosen in configuration. If they do not agree, an interface error exists.
3	CONFIGURATION ERROR – The non-volatile configuration memory did not agree with the data last saved. Default configuration data is then used and the scanner continues operating.
4	COMMUNICATION ERROR – The RS232 data line is being held active. The scanner will abort attempts to enter configuration mode after a short timeout.
5	COPROCESSOR COMMUNICATION ERROR – The main microprocessor is not communicating with the interface coprocessor. Return the unit for repair at an authorized service center.
6	LASER ERROR – The laser in the scanning system denotes a failure. Return the unit for repair at an authorized service center.
7	MOTOR ERROR – The motor in the scanning system denotes a failure. Return the unit for repair at an authorized service center.
8	SCALE ERROR – The scanner is not communicating with the scale.
9	EAS ERROR – The scanner is not communicating with the EAS device.

SCANNER OPERATION

POWER SAVE MODES

The 7820 bar code scanner has five configurable power save modes. Refer to the *MetroSelect Configuration Guide* for additional information on Power Save Modes.

- Blink Power Save Mode:**
“Blinks” the laser OFF & ON after a configured period of non-use.
When the scanner recognizes a bar code, it will exit the Blink mode.
- Laser Off Power Save Mode (Default):**
Turns the laser OFF after a configured period of non-use.
The motor continues to spin allowing for a faster “wake” up time. Pressing any of the three buttons will “wake” the scanner from the *Laser Off* power save mode (see figure 17).
- Laser & Motor Off Power Save Mode:**
Turns the laser and motor OFF after a configured period of non-use.
Pressing any of the three buttons will “wake” the scanner from the power save mode (see figure 37). This mode’s “wake up” time is slightly longer due to the motor’s need to restart.
- Dual Action Power Save Mode #1:**
“Blinks” the laser OFF & ON after a configured period of non-use turns the laser and motor OFF at thirty-minute intervals.

Example:

If the power save timeout is set to 15 minutes.

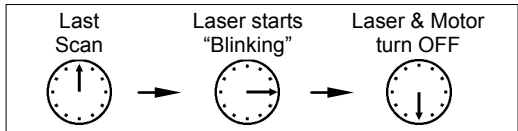

Pressing the Power Save button will “wake” the scanner from the power save mode (see figure 37).

- Dual Action Power Save Mode #2:**
Turns the laser OFF after a configured period of non-use then turns the motor OFF after thirty-minute intervals.

Example:

If the power save timeout is set to 15 minutes.

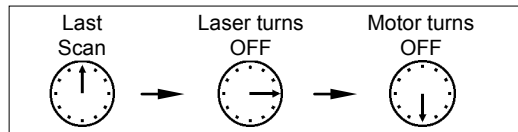

Pressing the Power Save button will “wake” the scanner from the power save mode (see figure 37).

SCANNER OPERATION

TOUCH BUTTON PANEL

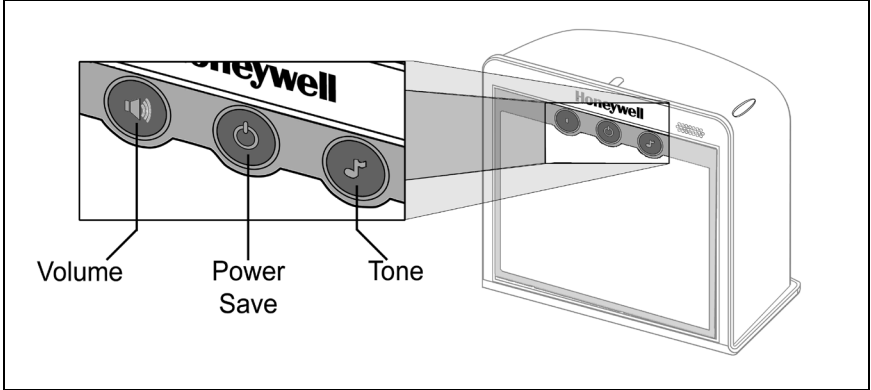

Figure 34. The Touch Button Panel Operation



Figure 35. Changing the Beeper Tone

CHANGING THE BEEPER TONE

Touch the Tone button once and the beeper tone will change. The new tone will be heard. Then two more of the new tones will be heard signifying the new setting has been set.



Figure 36. Changing the Beeper Volume

CHANGING THE BEEPER VOLUME

Touch the Volume Button to adjust the scanner's speaker volume or mute (silence) the scanner.

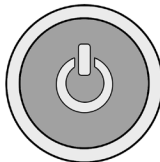

Figure 37. Power Save Button

PLACING THE UNIT IN POWER SAVE MODE

Long (>3 seconds) touch of the Power Save button will place the 7820 scanner into Power Save Mode.

TO WAKE THE UNIT FROM POWER SAVE MODE

Touch any of the three touch panel buttons to awaken the scanner for normal operation.

MAINTENANCE

REPLACEABLE PROTECTIVE OUTER WINDOW

The 7820 bar code scanner includes a replaceable protective outer window, which protects the flat-screen window from scratches when used in harsh scanning environments.

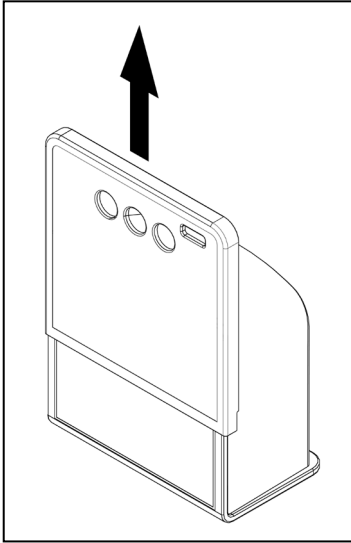

Figure 39.
Replaceable Protective Outer Window Easy Removal.

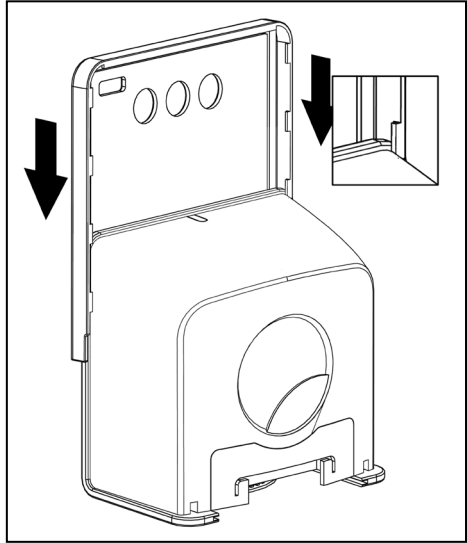

Figure 38.
Replaceable Protective Outer Window Easy Installation.

DAILY MAINTENANCE

Smudges and dirt on the unit's window can interfere with the unit's performance. If the window requires cleaning, use only a mild glass cleaner containing no ammonia. When cleaning the window, spray the cleaner onto a lint free, non-abrasive cleaning cloth then gently wipe the window clean.

If the unit's case requires cleaning, use a mild cleaning agent that does not contain strong oxidizing chemicals. Strong cleaning agents may discolor or damage the unit's exterior.

TROUBLESHOOTING GUIDE

The following guide is for reference purposes only. Contact a customer service representative to preserve the limited warranty terms on page 55.

7820 SERIES TROUBLESHOOTING GUIDE		
SYMPTOMS	POSSIBLE CAUSE(S)	SOLUTION
<i>All Interfaces</i>		
No LEDs, beep or motor spin.	No power is being supplied to the scanner.	Check transformer, outlet and power strip. Make sure the cable is plugged into the scanner.
No LEDs, beep.	No power is being supplied to the scanner from host.	Some host systems cannot supply enough current to power 7820 series scanner. Use the power supply included with the scanner.
3 beeps on power up.	Non-volatile RAM failure.	Contact a customer service representative, if the unit will not hold the configuration.
Continuous razz tone on power up.	Diagnostic failure.	Contact a customer service representative, if the unit will not function.
Razz tone and blue LED flash at power up.	VLD failure.	Contact a customer service representative.
	Scanner motor failure.	Contact a customer service representative.
Multiple scans upon presentation of code.	Same symbol timeout set too short.	Adjust same symbol timeout for a longer time.
The unit powers up but does not beep.	Beeper disabled No volume is selected No tone is selected.	Enable beeper. Select volume (configurable). Select tone.

TROUBLESHOOTING GUIDE

SYMPTOMS	POSSIBLE CAUSE(S)	SOLUTION
<p>The unit powers up, but does not scan and/or beep.</p>	<p>Scanning a particular symbology that is not enabled.</p>	<p>UPC/EAN, Code 39, Interleaved 2 of 5, Code 93, Code 128 and Codabar are enabled by default. Verify that the type of bar code being read has been selected.</p>
	<p>The scanner has been configured for a character length lock, or a minimum length and bar code being scanned does not satisfy the configured criteria.</p>	<p>Verify that the bar code that is being scanned falls into the criteria. (Typical of Non-UPC/EAN codes. <i>The scanner defaults to a minimum of 4 character bar code.</i>)</p>
<p>The unit scans a bar code, but locks up after the first scan (blue LED stays off).</p>	<p>The scanner is configured to support some form of host handshaking but is not receiving the signal.</p>	<p>If the scanner is setup to support ACK/NAK, RTS/CTS, XON/XOFF or D/E, verify that the host cable and host are supporting the handshaking properly.</p>
<p>The unit scans, but the data transmitted to the host is incorrect.</p>	<p>The scanner's data format does not match the host system requirements.</p>	<p>Verify that the scanner's data format matches the format required by the host. Make sure that the scanner is connected to the proper host port.</p>

TROUBLESHOOTING GUIDE

SYMPTOMS	POSSIBLE CAUSE(S)	SOLUTION
Scanner beeps at some bar codes and NOT for others of the same bar code symbology.	The bar code may have been printed incorrectly.	Check if it is a check digit/character/or border problem.
	The scanner is not configured correctly for this type of bar code.	Check if check digits are set properly.
	The minimum symbol length setting does not work with the bar code.	Check if the correct minimum symbol length is set.
Multi-Function Button is not working.	A faulty push button switch.	Contact a customer service representative.
<i>Keyboard Wedge Only</i>		
The unit scans the bar code but there is no data.	Configuration is not correct.	Make sure the scanner is configured for the appropriate mode.
The unit scans but the data is not correct.	Configuration is not correct.	Make sure that the proper PC type AT or PS2 is selected. Verify correct country code and data formatting are selected. Adjust the intercharacter delay.
The unit is not transmitting each character.	Configuration is not correct.	Increase the interscan code delay setting. Adjust whether the F0 break is transmitted. It may be necessary to try this in both settings.
Alpha characters show as lower case.	Computer is in Caps Lock mode.	Enable Caps Lock detect setting of the scanner to detect whether the PC is operating in Caps Lock.

TROUBLESHOOTING GUIDE

SYMPTOMS	POSSIBLE CAUSE(S)	SOLUTION
Everything works except for a couple of characters.	These characters may not be supported by that country's key look up table.	Try operating the scanner in Alt mode.
RS232 Only		
The unit is not transmitting each character.	Configuration is not correct.	Increase the intercharacter delay setting. Adjust whether the F0 break is transmitted (KBW Interface ONLY). It may be necessary to try this in both settings.
Alpha characters show as lower case.	Computer is in Caps Lock mode.	Enable the caps lock detect setting of the scanner to detect if the PC is operating in Caps Lock.
Power-up OK and scans OK but does not communicate properly to the host.	Com port at the host is not working or configured properly.	Check to make sure that the baud rate and parity of the scanner and the communication port match and the program is looking for "RS232" data.
	Com port not operating properly.	
	Cable not connected to the proper com port.	
The host is receiving data but the data does not look correct.	The scanner and host may not be configured for the same interface.	Check that the scanner and the host are configured for the same interface.

TROUBLESHOOTING GUIDE

SYMPTOMS	POSSIBLE CAUSE(S)	SOLUTION
Aux Port Operation with any Interface		
Trouble with the secondary scanner.		Refer to the user guide provided with the secondary scanner.
Secondary scanner powers up but data is not relayed to the host.	Cable [PN 57-57499x-3] may not be connected to the proper port.	Ensure the secondary scanner is connected to the 7820 com port marked "Aux" port.
	The "Aux" com port may not be operating properly.	* The 7820 must be configured to enable the "Aux" port.
		The secondary scanner must be configured to send 'secondary' formatted data (reserve code 32).
* Use the "Auxiliary mode setup" wizard in MetroSet®.		
USB Only		
The scanner powers up ok, scans ok but does not communicate.	The USB Port is not operating correctly.	<p>Check that the scanner is configured for USB operation.</p> <p>Check that the host's USB port is enabled.</p>

CONFIGURATION MODES

The 7820 has three modes of configuration.

- **Bar Codes**
Configure the 7820 by scanning the bar codes included in the MetroSelect Configuration Guide shipped with the area imager.
This manual is available for download at www.honeywellaidc.com.
- **MetroSet2**
This user-friendly Windows-based configuration program allows you to simply 'point-and-click' at the desired scanner options. This program is available for download at www.honeywellaidc.com.
- **Serial Programming**
This mode of configuration is ideal for OEM applications. This mode gives the end-user the ability to send a series of commands using the serial port of the host system. The commands are equivalent to the numerical values of the bar codes located in the MetroSelect Configuration Guide.

UPGRADING THE FIRMWARE

The 7820 is part of Honeywell's line of scanners with flash upgradeable firmware. The upgrade process requires, a new firmware file supplied to the customer by a customer service representative♦ and Honeywell's MetroSet2 software♦♦. A personal computer running Microsoft® Windows® 95 or greater with an available RS232 serial or USB port is required to complete the upgrade.



PowerLink Cable #54-54014 is required when using RS232 for the upgrade process. **Do not** use the standard cable supplied with keyboard wedge or RS485 scanner interface kits. If using USB for the upgrade process, the standard USB cable provided with the scanner can be used.

To upgrade the firmware in the 7820:

1. Plug the scanner into a serial communication port on the host system.
2. Start the MetroSet2 software.
3. Click on the plus sign (+) next to *POS Scanners* to expand the supported scanner list.
4. Choose the 7820 Solaris from the list.
5. Click on the *Configure Solaris/7820 Scanner* button.
6. Choose *Flash Utility* from the options list located on the left side of the screen.
7. Click on the *Open File* button in the Flash Utility window.
8. Locate and open the flash upgrade file supplied.
9. Select the COM port that the scanner is connected to on the host system.
10. Verify the settings listed in the Flash Utility window.
11. Click on the *Flash Scanner* button to begin the flash upgrade.
12. A message will appear on the screen when the upgrade is complete.

- ♦ See Customer Support on page 53.
- ♦♦ MetroSet2 is available for download, at no additional cost, from www.honeywellaidc.com.

SCANNER AND CABLE TERMINATIONS

SCANNER PINOUT CONNECTIONS

The 7820 scanner interfaces terminate to 10-pin modular jacks located on the back of the unit.

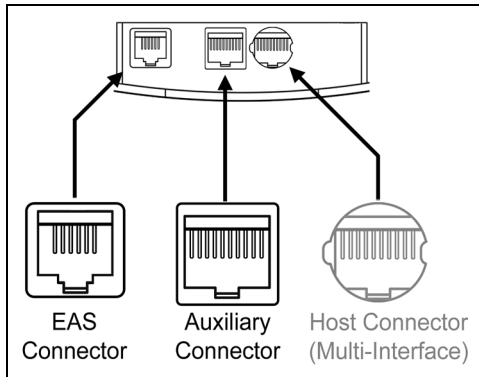

Figure 40. Scanner Interface Ports

7820 EAS Connector			7820 Auxiliary Connector	
Pin	Function		Pin	Function
1	GROUND		1	GROUND
2	ANTENNA +		2	AUX_RxD
3	ANTENNA -		3	AUX_TxD
4	EAS GPIO OUT		4	AUX_RTS
5	EAS GPIO IN		5	AUX_CTS
6	SHIELD		6	SCAN DATA
			7	TRIGGER
			8	SCAN ENABLE
			9	SW +5VDC (OUT)
			10	GROUND

SCANNER AND CABLE TERMINATIONS

SCANNER PINOUT CONNECTIONS

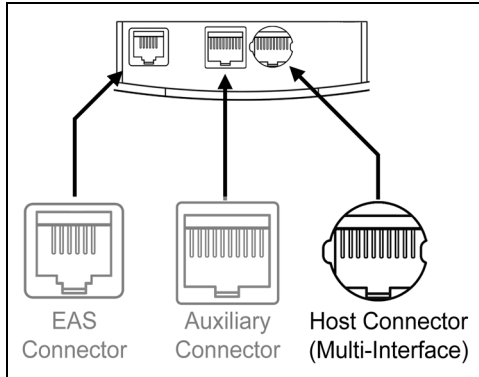

Figure 41. Scanner Interface Ports

HOST CONNECTOR (Multi-Interface)			
Pin	Function	Pin	Function
RS232		Keyboard Wedge	
1	Ground	1	Ground
2	CTS / DTR	2	Tied to Pin 3 in Cable
3	Data Rx	3	Tied to Pin 2 in Cable
4	N/C	4	PC Data
5	N/C	5	PC Clock
6	RTS*	6	KB Clock
7	N/C	7	+5VDC PC Keyboard
8	Data Rx*	8	KB Data
9	Adapter Power	9	Adapter Power
10	Shield Ground	10	Shield Ground
RS485		USB	
1	Ground	1	Ground
2	Tied to Pin 6 in Cable	2	Tied to Pin 4 in Cable
3	N/C	3	N/C
4	IBM A+	4	Tied to Pin 2 in Cable
5	IBM B-	5	N/C
6	Tied to Pin 2 in Cable	6	USB D+
7	N/C	7	+5VDC USB
8	N/C	8	USB D-
9	Adapter Power	9	Adapter Power
10	Shield Ground	10	Shield Ground

* These signals are TTL level outputs.

SCANNER AND CABLE TERMINATIONS

CABLE CONNECTOR CONFIGURATIONS (HOST END)

VLink Cable, PN 5S-5Sxxx-3*	
Pin	Function
1	Shield Ground
2	RS232 Transmit Output
3	RS232 Receive Input
4	N/C
5	Power/Signal Ground
6	Reserved
7	CTS Input †
8	RTS Output
9	+5VDC

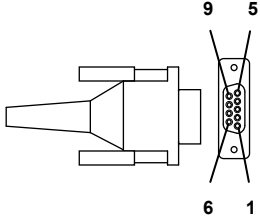

9-Pin D-Type Conn.

xxx* specifies connection to the host

USB Type A, VLink Cable PN 5S-5S235-3	
Pin	Function
1	+5VDC
2	D-
3	D+
4	Ground



USB Type A

USB Direct 12V (Type A) Locking PN 5S-5S213-N-3	
Pin	Function
1	+5VDC
2	D-
3	D+
4	Ground
5	Ground
6	+12VDC
7-8	N/C

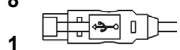

USB Type A. Locking

VLink, RS232 AUX Cable, PN 57-57499-3	
Pin	Function
1	Ground
2	RS232 Transmit Output
3	RS232 Receive Input
4	RTS Output
5	CTS Input
6-8	N/C
9	+5VDC
10	Shield Ground

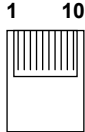



10-pin Modular Plug

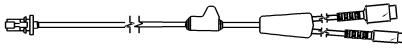

† CTS Input can also serve as DTR input.

SCANNER AND CABLE TERMINATIONS

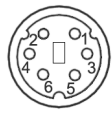
CABLE CONNECTOR CONFIGURATIONS (HOST END)

VLink, Keyboard Wedge PN 54-54002		
Pin	Function	 5-Pin DIN, Female
1	Keyboard Clock	
2	Keyboard Data	
3	No Connect	
4	Power Ground	
5	+5 Volts DC	 6-Pin DIN, Male
Pin	Function	
1	Keyboard Data	
2	No Connect	
3	Power Ground	
4	+5 Volts DC	
5	PC Clock	
6	No Connect	

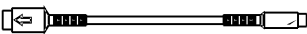
Honeywell will supply an adapter cable with a 5-pin DIN male connector on one end and a 6-pin mini DIN female connector on the other. According to the termination required, connect the appropriate end of the adapter cable to the VLink cable, leaving the necessary termination exposed for connecting to the keyboard and the keyboard port on the PC.

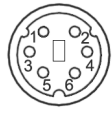
Keyboard Wedge Adapter Cable		
Pin	Function	 5-Pin DIN, Male
1	PC Clock	
2	PC Data	
3	No Connect	
4	Power Ground	
5	+5 Volts DC	 6-pin Mini DIN, Female
Pin	Function	
1	Keyboard Data	
2	No Connect	
3	Power Ground	
4	+5 Volts DC	
5	Keyboard Clock	
6	No Connect	

SAFETY

ITE Equipment

IEC 60950-1, EN 60950-1

Laser

Laser Class 1: IEC 60825-1:1993+A1+A2,
EN 60825-1:1994+A1+A2



⚠ Caution

Use of controls or adjustments or performance of procedures other than those specified herein may result in hazardous laser light exposure. Under no circumstances should the customer attempt to service the laser scanner. Never attempt to look at the laser beam, even if the scanner appears to be nonfunctional. Never open the scanner in an attempt to look into the device. Doing so could result in hazardous laser light exposure. The use of optical instruments with the laser equipment will increase eye hazard.

⚠ Atención

La modificación de los procedimientos, o la utilización de controles o ajustes distintos de los especificados aquí, pueden provocar una luz de láser peligrosa. Bajo ninguna circunstancia el usuario deberá realizar el mantenimiento del láser del escáner. Ni intentar mirar al haz del láser incluso cuando este no esté operativo. Tampoco deberá abrir el escáner para examinar el aparato. El hacerlo puede conllevar una exposición peligrosa a la luz de láser. El uso de instrumentos ópticos con el equipo láser puede incrementar el riesgo para la vista.

⚠ Attention

L'emploi de commandes, réglages ou procédés autres que ceux décrits ici peut entraîner de graves irradiations. Le client ne doit en aucun cas essayer d'entretenir lui-même le scanner ou le laser. Ne regardez jamais directement le rayon laser, même si vous croyez que le scanner est inactif. N'ouvrez jamais le scanner pour regarder dans l'appareil. Ce faisant, vous vous exposez à une rayonnement laser qui est dangereux. L'emploi d'appareils optiques avec cet équipement laser augmente le risque d'endommagement de la vision.

⚠ Achtung

Die Verwendung anderer als der hier beschriebenen Steuerungen, Einstellungen oder Verfahren kann eine gefährliche Laserstrahlung hervorrufen. Der Kunde sollte unter keinen Umständen versuchen, den Laser-Scanner selbst zu warten. Sehen Sie niemals in den Laserstrahl, selbst wenn Sie glauben, daß der Scanner nicht aktiv ist. Öffnen Sie niemals den Scanner, um in das Gerät hineinzusehen. Wenn Sie dies tun, können Sie sich einer gefährlichen Laserstrahlung aussetzen. Der Einsatz optischer Geräte mit dieser Laserausrüstung erhöht das Risiko einer Sehschädigung.

⚠ Attenzione

L'utilizzo di sistemi di controllo, di regolazioni o di procedimenti diversi da quelli descritti nel presente Manuale può provocare delle esposizioni a raggi laser rischiose. Il cliente non deve assolutamente tentare di riparare egli stesso lo scanner laser. Non guardate mai il raggio laser, anche se credete che lo scanner non sia attivo. Non aprite mai lo scanner per guardare dentro l'apparecchio. Facendolo potete esporVi ad una esposizione laser rischiosa. L'uso di apparecchi ottici, equipaggiati con raggi laser, aumenta il rischio di danni alla vista.

REGULATORY COMPLIANCE

EMC

Emissions

FCC Part 15, ICES-003, CISPR 22, EN 55022

Immunity

CISPR 24, EN 55024

Changes or modifications not expressly approved by the party responsible for compliance could void the user's authority to operate the equipment.

Class A Devices

The following is applicable when the scanner cable is greater in length than 3 meters (9.8 feet) when fully extended:

Les instructions ci-dessous s'appliquent aux câbles de scanner dépassant 3 mètres (9.8 pieds) de long en extension maximale:

Folgendes trifft zu, wenn das Scannerkabel länger als 3 Meter ist:

This equipment has been tested and found to comply with limits for a Class A digital device, pursuant to part 15 of the FCC Rules. These limits are designed to provide reasonable protection against harmful interference when the equipment is operated in a commercial environment. This equipment generates, uses and can radiate radio frequency energy and, if not installed and used in accordance with the instruction manual, may cause harmful interference to radio communications. Operation of this equipment in a residential area is likely to cause harmful interference, in which case the user will be required to correct the interference at their own expense. Any unauthorized changes or modifications to this equipment could void the user's authority to operate this device.

This device complies with part 15 of the FCC Rules. Operation is subject to the following two conditions: (1) This device may not cause harmful interference, and (2) this device must accept any interference received, including interference that may cause undesired operation.

Notice

This Class A digital apparatus complies with Canadian ICES-003.

Remarque

Cet appareil numérique de classe A est conforme à la norme canadienne NMB-003.

European Standard

Warning

This is a class A product. In a domestic environment this product may cause radio interference in which case the user may be required to take adequate measures.

Funkstöreigenschaften nach EN55022:1998

Warnung!

Dies ist eine Einrichtung der Klasse A. Diese Einrichtung kann im Wohnbereich Funkstörungen verursachen. In diesem Fall kann vom Betreiber verlangt werden, angemessene Massnahmen durchzuführen.

Standard Europeo

Attenzione

Questo e' un prodotto di classe A. Se usato in vicinanza di residenze private potrebbe causare interferenze radio che potrebbero richiedere all'utilizzatore opportune misure.

Attention

Ce produit est de classe "A". Dans un environnement domestique, ce produit peut être la cause d'interférences radio. Dans ce cas l'utilisateur peut être amené à prendre les mesures adéquates.

EMC

Changes or modifications not expressly approved by the party responsible for compliance could void the user's authority to operate the equipment.

Class B Devices

The following is applicable when the scanner cable is less than 3 meters (9.8 feet) in length when fully extended:

Les instructions ci-dessous s'appliquent aux câbles de scanner ne dépassant pas 3 mètres (9.8 pieds) de long en extension maximale:

Folgendes trifft zu, wenn das Scannerkabel kürzer als 3 Meter ist:

This device complies with Part 15 of the FCC Rules. Operation is subject to the following two conditions: (1) This device may not cause harmful interference, and (2) this device must accept any interference received, including interference that may cause undesired operation.

This equipment has been tested and found to comply with the limits for a Class B digital device, pursuant to Part 15 of the FCC rules. These limits are designed to provide reasonable protection against harmful interference in a residential installation. This equipment generates, uses and can radiate radio frequency energy and, if not installed and used in accordance with the instructions, may cause harmful interference to radio communications. However, there is no guarantee that interference will not occur in a particular installation. If this equipment does cause harmful interference to radio or television reception, which can be determined by turning the equipment off and on, the user is encouraged to try to correct the interference by one or more of the following measures:

- Reorient or relocate the receiving antenna
- Increase the separation between the equipment and receiver
- Connect the equipment into an outlet on a circuit different from that to which the receiver is connected
- Consult the dealer or an experienced radio/TV technician for help

Notice

This Class B digital apparatus complies with Canadian ICES-003.

Remarque

Cet appareil numérique de classe B est conforme à la norme canadienne NMB-003.

Product Service and Repair

Honeywell International Inc. provides service for all its products through service centers throughout the world. To obtain warranty or non-warranty service, contact the appropriate location below to obtain a Return Material Authorization number (RMA #) before returning the product.

North America

Telephone: (800) 782-4263

E-mail: hsmnaservice@honeywell.com

Latin America

Telephone: (803) 835-8000

Telephone: (800) 782-4263

Fax: (239) 263-9689

E-mail: laservice@honeywell.com

Brazil

Telephone: +55 (21) 3535-9100

Fax: +55 (21) 3535-9105

E-mail: brservice@honeywell.com

Mexico

Telephone: 01-800-HONEYWELL (01-800-466-3993)

Fax: +52 (55) 5531-3672

E-mail: mxservice@honeywell.com

Europe, Middle East, and Africa

Telephone: +31 (0) 40 2901 633

Fax: +31 (0) 40 2901 631

E-mail: euroservice@honeywell.com

Hong Kong

Telephone: +852-29536436

Fax: +851-2511-3557

E-mail: apservice@honeywell.com

Singapore

Telephone: +65-6842-7155

Fax: +65-6842-7166

E-mail: apservice@honeywell.com

China

Telephone: +86 800 828 2803

Fax: +86-512-6762-2560

E-mail: apservice@honeywell.com

Japan

Telephone: +81-3-3839-8511

Fax: +81-3-3839-8519

E-mail: apservice@honeywell.com

Online Product Service and Repair Assistance

You can also access product service and repair assistance online at www.honeywellaidc.com.

Technical Assistance

If you need assistance installing or troubleshooting your device, please call your distributor or the nearest technical support office:

North America/Canada

Telephone: (800) 782-4263

E-mail: hsmnasupport@honeywell.com

Latin America

Telephone: (803) 835-8000

Telephone: (800) 782-4263

E-mail: hsmlasupport@honeywell.com

Brazil

Telephone: +55 (21) 3535-9100

Fax: +55 (21) 3535-9105

E-mail: brsuporte@honeywell.com

Mexico

Telephone: 01-800-HONEYWELL (01-800-466-3993)

E-mail: soporte.hsm@honeywell.com

Europe, Middle East, and Africa

Telephone: +31 (0) 40 7999 393

Fax: +31 (0) 40 2425 672

E-mail: hsmeurosupport@honeywell.com

Hong Kong

Telephone: +852-29536436

Fax: +851-2511-3557

E-mail: aptechsupport@honeywell.com

Singapore

Telephone: +65-6842-7155

Fax: +65-6842-7166

E-mail: aptechsupport@honeywell.com

China

Telephone: +86 800 828 2803

Fax: +86-512-6762-2560

E-mail: aptechsupport@honeywell.com

Japan

Telephone: +81-3-3839-8511

Fax: +81-3-3839-8519

E-mail: aptechsupport@honeywell.com

Online Technical Assistance

You can also access technical assistance online at www.honeywellaidc.com.

LIMITED WARRANTY

Honeywell International Inc. ("HII") warrants its products and optional accessories to be free from defects in materials and workmanship and to conform to HII's published specifications applicable to the products purchased at the time of shipment. This warranty does not cover any HII product which is (i) improperly installed or used; (ii) damaged by accident or negligence, including failure to follow the proper maintenance, service, and cleaning schedule; or (iii) damaged as a result of (A) modification or alteration by the purchaser or other party, (B) excessive voltage or current supplied to or drawn from the interface connections, (C) static electricity or electro-static discharge, (D) operation under conditions beyond the specified operating parameters, or (E) repair or service of the product by anyone other than HII or its authorized representatives.

This warranty shall extend from the time of shipment for the duration published by HII for the product at the time of purchase ("Warranty Period"). Any defective product must be returned (at purchaser's expense) during the Warranty Period to HII factory or authorized service center for inspection. No product will be accepted by HII without a Return Materials Authorization, which may be obtained by contacting HII. In the event that the product is returned to HII or its authorized service center within the Warranty Period and HII determines to its satisfaction that the product is defective due to defects in materials or workmanship, HII, at its sole option, will either repair or replace the product without charge, except for return shipping to HII.

EXCEPT AS MAY BE OTHERWISE PROVIDED BY APPLICABLE LAW, THE FOREGOING WARRANTY IS IN LIEU OF ALL OTHER COVENANTS OR WARRANTIES, EITHER EXPRESSED OR IMPLIED, ORAL OR WRITTEN, INCLUDING, WITHOUT LIMITATION, ANY IMPLIED WARRANTIES OF MERCHANTABILITY OR FITNESS FOR A PARTICULAR PURPOSE, OR NON-INFRINGEMENT.

HII'S RESPONSIBILITY AND PURCHASER'S EXCLUSIVE REMEDY UNDER THIS WARRANTY IS LIMITED TO THE REPAIR OR REPLACEMENT OF THE DEFECTIVE PRODUCT WITH NEW OR REFURBISHED PARTS. IN NO EVENT SHALL HII BE LIABLE FOR INDIRECT, INCIDENTAL, OR CONSEQUENTIAL DAMAGES, AND, IN NO EVENT, SHALL ANY LIABILITY OF HII ARISING IN CONNECTION WITH ANY PRODUCT SOLD HEREUNDER (WHETHER SUCH LIABILITY ARISES FROM A CLAIM BASED ON CONTRACT, WARRANTY, TORT, OR OTHERWISE) EXCEED THE ACTUAL AMOUNT PAID TO HII FOR THE PRODUCT. THESE LIMITATIONS ON LIABILITY SHALL REMAIN IN FULL FORCE AND EFFECT EVEN WHEN HII MAY HAVE BEEN ADVISED OF THE POSSIBILITY OF SUCH INJURIES, LOSSES, OR DAMAGES. SOME STATES, PROVINCES, OR COUNTRIES DO NOT ALLOW THE EXCLUSION OR LIMITATIONS OF INCIDENTAL OR CONSEQUENTIAL DAMAGES, SO THE ABOVE LIMITATION OR EXCLUSION MAY NOT APPLY TO YOU.

All provisions of this Limited Warranty are separate and severable, which means that if any provision is held invalid and unenforceable, such determination shall not affect the validity of enforceability of the other provisions hereof. Use of any peripherals not provided by the manufacturer may result in damage not covered by this warranty. This includes but is not limited to: cables, power supplies, cradles, and docking stations. HII extends these warranties only to the first end-users of the products. These warranties are non-transferable.

The duration of the limited warranty for the 7820 Solaris is two (2) years. The accessories have a 90 day limited warranty from the date of manufacture.

INDEX

A

AC	8
accessories	3, 4
adapter	49
audible	<i>See indicator</i>
auxiliary	3, 43, 47, 48
scanner	16, 17, 18
auxiliary port	10

B

bar code	28, 29, 30, 31
Bar Code	44
beep	<i>See indicator</i>
blue led	<i>See indicator</i>
button	
power save button	9, 36
tone button	9
volume button	9
Button	45

C

cable	7, 9
adapter	49
auxiliary	3
communication	3, 4, 46–49
connection area	9
cover	9
EAS	3
keyboard wedge	46–49
pin assignments	46–49
powerlink	3, 4, 46–49
stand-alone keyboard	3
USB	3, 46–49
caution	11, 50
class	52
cleaning	38
communication	2
compliance	50, 51
configuration	45
Configuration	44
connector panel	10
customer service	55

D

DC power	10
depth of field	7, 28, 29, 30, 31
diagnostic	35
dimensions	7, 10

E

EAS	3, 10, 19
-----	-----------

EAS

EMC	51
EMI	51
emissions	51
error code	35

F

features	1
firmware	45
flash	45
flex stand	
installation	20–22, 20–22
optional kits	5

H

HID	13
Host	16

I

immunity	51
indicator	7
audible	9, 32, 34, 39–43, 45
diagnostic	35
failure	32, 34, 39–43
visual	9, 33, 39–43, 45
installation	
cable	12–18
EAS	19
flex stand	20–22, 20–22
outer window	38
interface	7
light pen	14, 46
RS232	14
RS485	15, 46
stand-alone keyboard	47
USB	13

K

kb wedge	<i>See keyboard wedge</i>
keyboard type	2
keyboard wedge	2–3, 10, 41, 47, 49
kits	5, 6

L

labels	11
laser	11, 36, 50
laser power	7
led	<i>See indicator</i>
limited warranty	55

INDEX

M

maintenance	38
manual	3
MetroSelect	44
MetroSet2	45

N

notices	52
---------------	----

O

operation	52
-----------------	----

P

pin assignments	<i>See cables</i>
POS (Point Of Sale)	13
power	8, 45
power save	36
protocols	2

R

razzberry tone	32, 33, 34
repair	55
RS232	10, 14, 42, 46–49
RS485	10

S

safety	50, 52
scan zone	27
secondary scanner	16, 17, 18, 43
serial label	11
specifications	7

T

tone	32, 33, 34
troubleshooting	39–43

U

upgrade	45
USB	3, 10, 13, 43, 47, 48

V

ventilation	8
visual	<i>See indicator</i>
voltage	8, 12, 14, 16

W

warranty	55
weight	7
window	9, 38
window, outer	38

Honeywell Scanning & Mobility

9680 Old Bailes Road

Fort Mill, SC 29707

www.honeywellaidc.com

